

A	12/23/15	INITIAL RELEASE	MW	DR
REV	DATE	DESCRIPTION	DWN	APVD
REVISIONS				
SEE TABLE		SEE TABLE		
MATERIAL/DESCRIPTION		PART NO.		

DIMENSIONS IN INCHES	FLEXSENSE CALIBRATION PANEL			
	PART NO. SCP-CF	FOR -		
TOLERANCES	-			
.0 ± .015" .00 ± .010" .000 ± .005"	-			
FRACTIONAL ALL ± .015"	-			
ANGLES ± 1/4"	-			
UNLESS OTHERWISE SPECIFIED	DATE 12/23/2015	SCALE NTS	SIZE B	SHEET 1 OF 4

**BARBEN ANALYTICAL** **AMETEK**  
5200 Convair Drive Carson City, NV 89706 PH(775)883-2500 FAX (775)297-4740

DRAWN BY M. WALSER ECO# DRAWING NO  
APVD BY D. RUSSELL - 2P0318

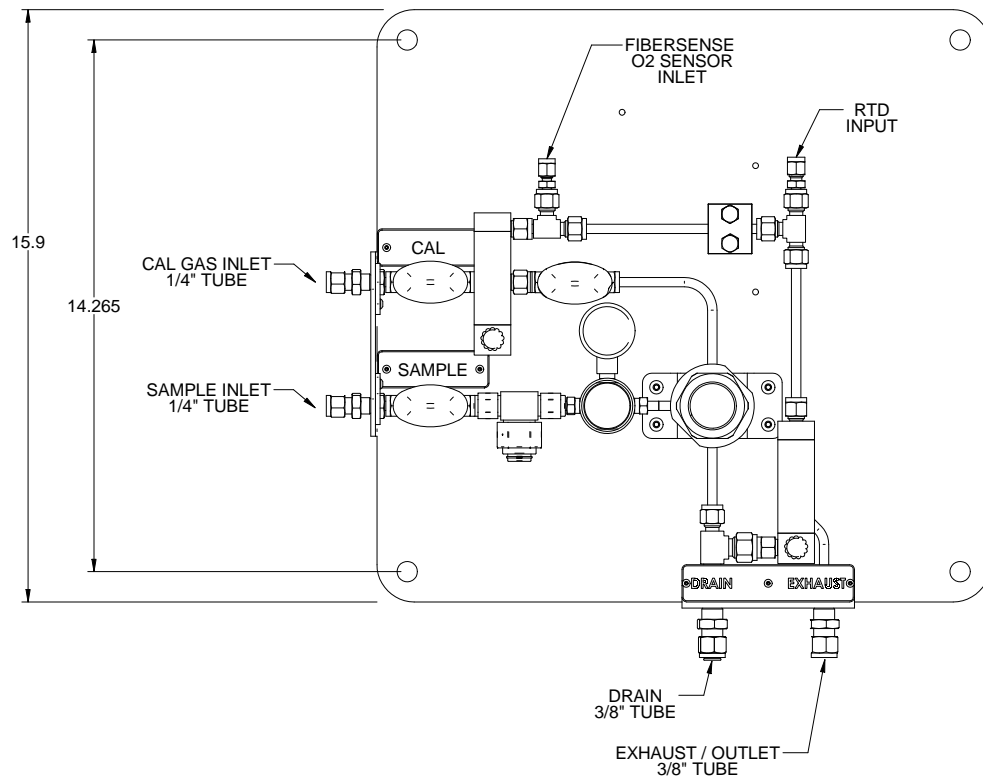
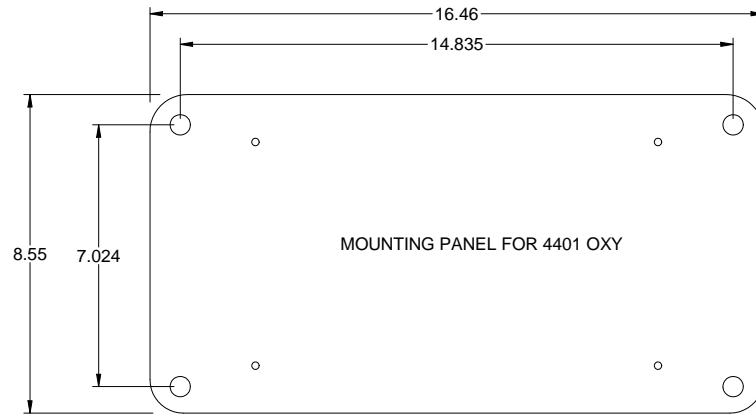

A	12/23/15	INITIAL RELEASE	MW	DR
REV	DATE	DESCRIPTION	DWN	APVD
REVISIONS				

SEE TABLE	SEE TABLE
MATERIAL/DESCRIPTION	PART NO.

DIMENSIONS IN INCHES	FLEXSENSE CALIBRATION PANEL			
	PART NO. SCP-CT	FOR -		
TOLERANCES				
FRACTIONAL ALL ± .015"	5200 Convair Drive Carson City, NV 89706 PH(775)883-2500 FAX (775)297-4740			
ANGLES ± 1/4"	DRAWN BY M. WALSER	ECO#	DRAWING NO	
UNLESS OTHERWISE SPECIFIED	APVD BY D. RUSSELL	-	2P0318	
	DATE 12/23/2015	SCALE NTS	SIZE B	SHEET 2 OF 4

PLUMB IN FIELD

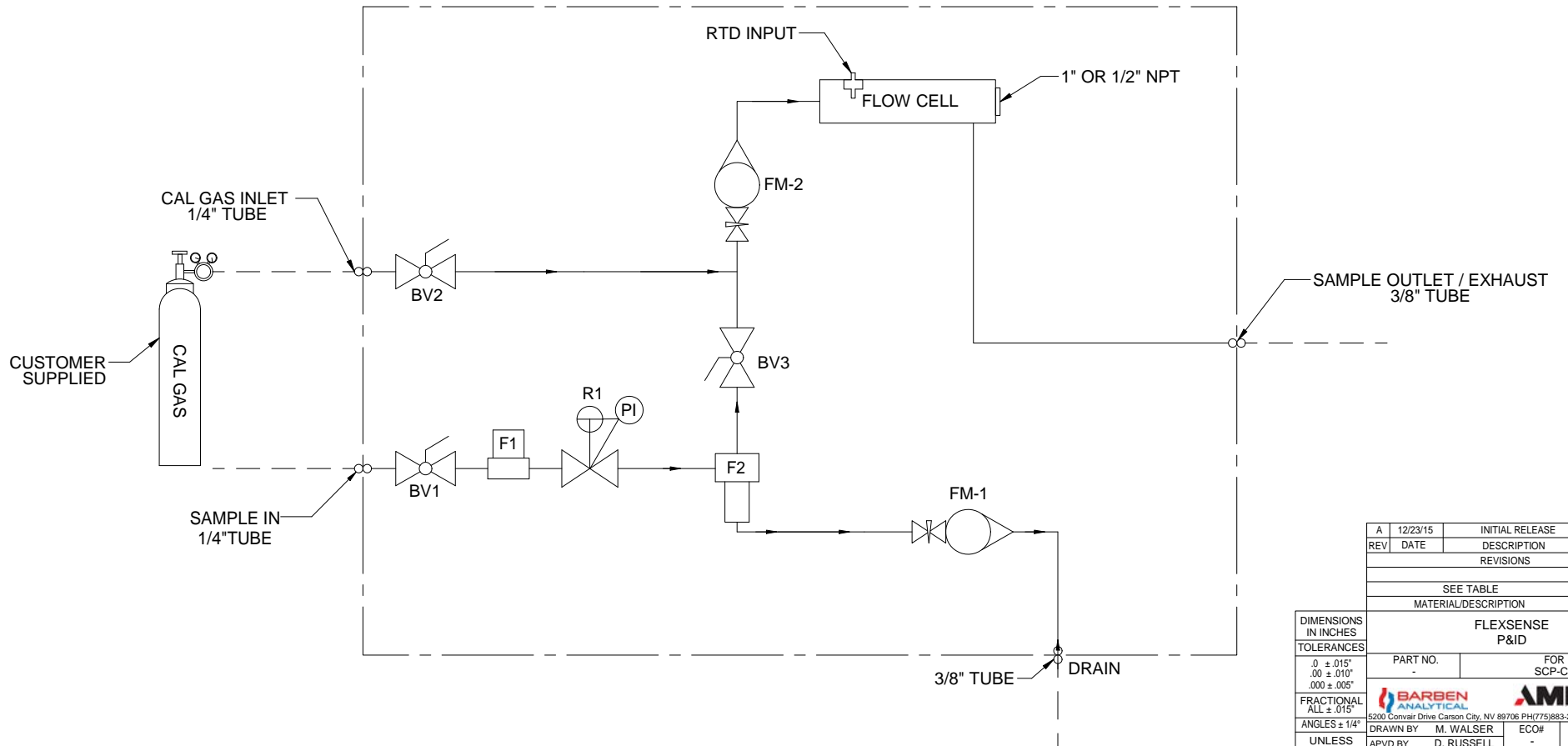

A	12/23/15	INITIAL RELEASE	MW	DR
REV	DATE	DESCRIPTION	DWN	APVD
REVISIONS				

SEE TABLE	SEE TABLE
MATERIAL/DESCRIPTION	PART NO.

FLEXSENSE P&ID	
PART NO.	FOR SCP-CF

DIMENSIONS IN INCHES
TOLERANCES
.0 ± .015"
.00 ± .010"
.000 ± .005"

FRACTIONAL ALL ± .015"
ANGLES ± 1/4"
UNLESS OTHERWISE SPECIFIED

5200 Convair Drive Carson City, NV 89706 PH(775)883-2500 FAX (775)297-4740			
DRAWN BY	M. WALSER	ECO#	DRAWING NO
APVD BY	D. RUSSELL	-	2P0318
DATE	12/23/2015	SCALE	SHEET
	NTS	B	3 OF 4

PLUMB IN FIELD

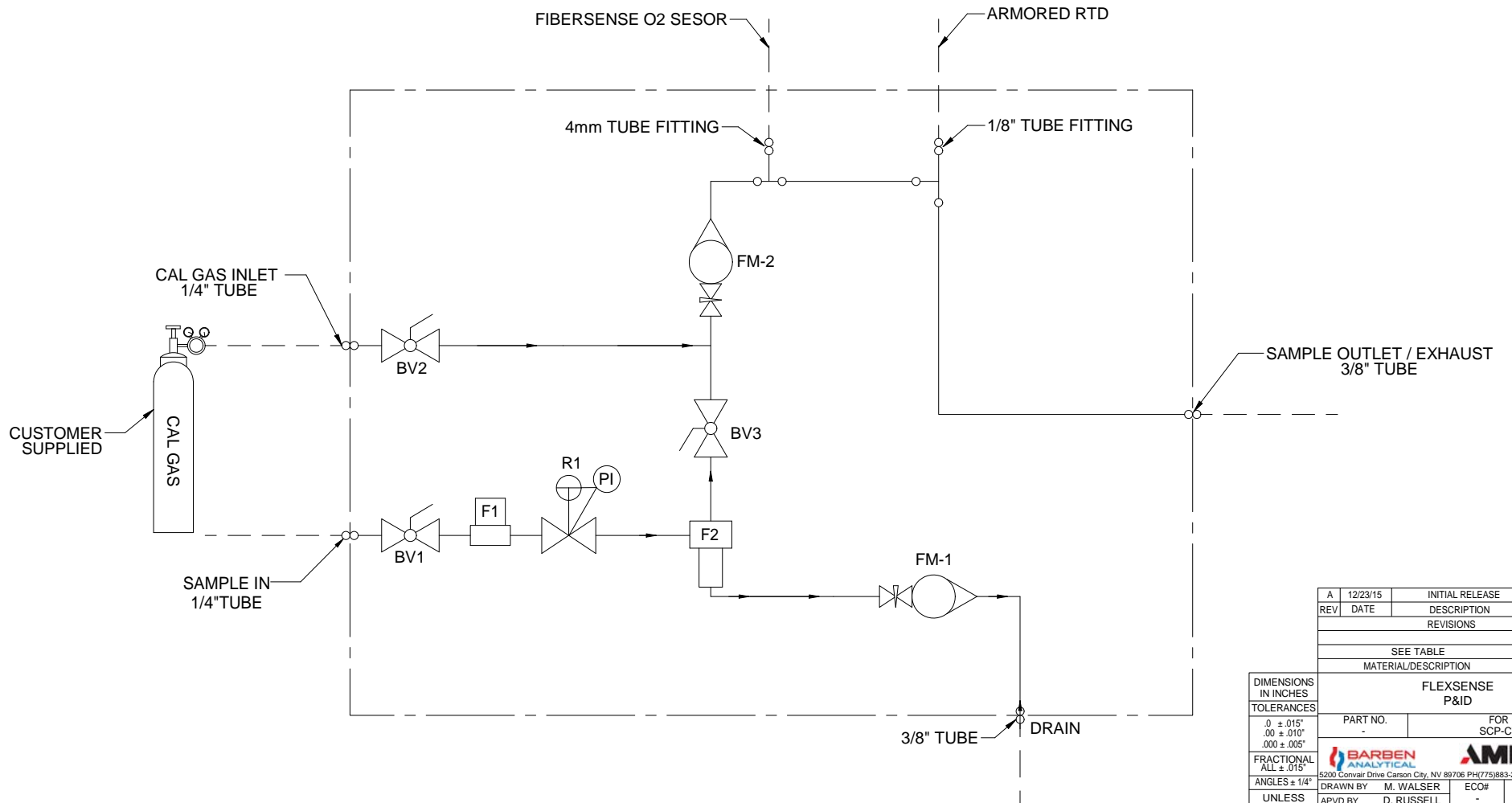

A	12/23/15	INITIAL RELEASE	MW	DR
REV	DATE	DESCRIPTION	DWN	APVD
REVISIONS				

SEE TABLE	SEE TABLE
MATERIAL/DESCRIPTION	PART NO.

FLEXSENSE P&ID	
PART NO.	FOR SCP-CT

DIMENSIONS IN INCHES
TOLERANCES

0 ± .015"
.00 ± .010"
.000 ± .005"

FRACTIONAL ALL ± .015"
------------------------

ANGLES ± 1/4"
UNLESS OTHERWISE SPECIFIED

<b>BARBEN ANALYTICAL</b>		<b>AMETEK</b>	
5200 Convair Drive Carson City, NV 89706 PH(775)883-2500 FAX (775)297-4740			
DRAWN BY	M. WALSER	ECO#	DRAWING NO
APVD BY	D. RUSSELL	-	2P0318
DATE	12/23/2015	SCALE	SHEET
	NTS	B	4 OF 4